

Safety Checklist after first assembly

● **Test intervals of Safety: 6 months**

● **Test Component and contents:**

1. Removing the reticulated system:
 - Check of removing condition each rope
 - Screwing the turn buckle and conversion the turnbuckle in anchors plate(see for this workstep turnbuckle assembly)
2. Abrasion condition of rope:
 - Checking of all rope surface
 - Strengthened of rope: Coating on the surface
3. Attachment condition of the anchors plate and turnbuckle
4. Screwing condition of all bolt
5. Galvanizing condition of the steel component:
 - Protection of steel component from corrosion.

● **Measure**

In case of the appearance the defect detail is repaired usually within 3 days after checking.

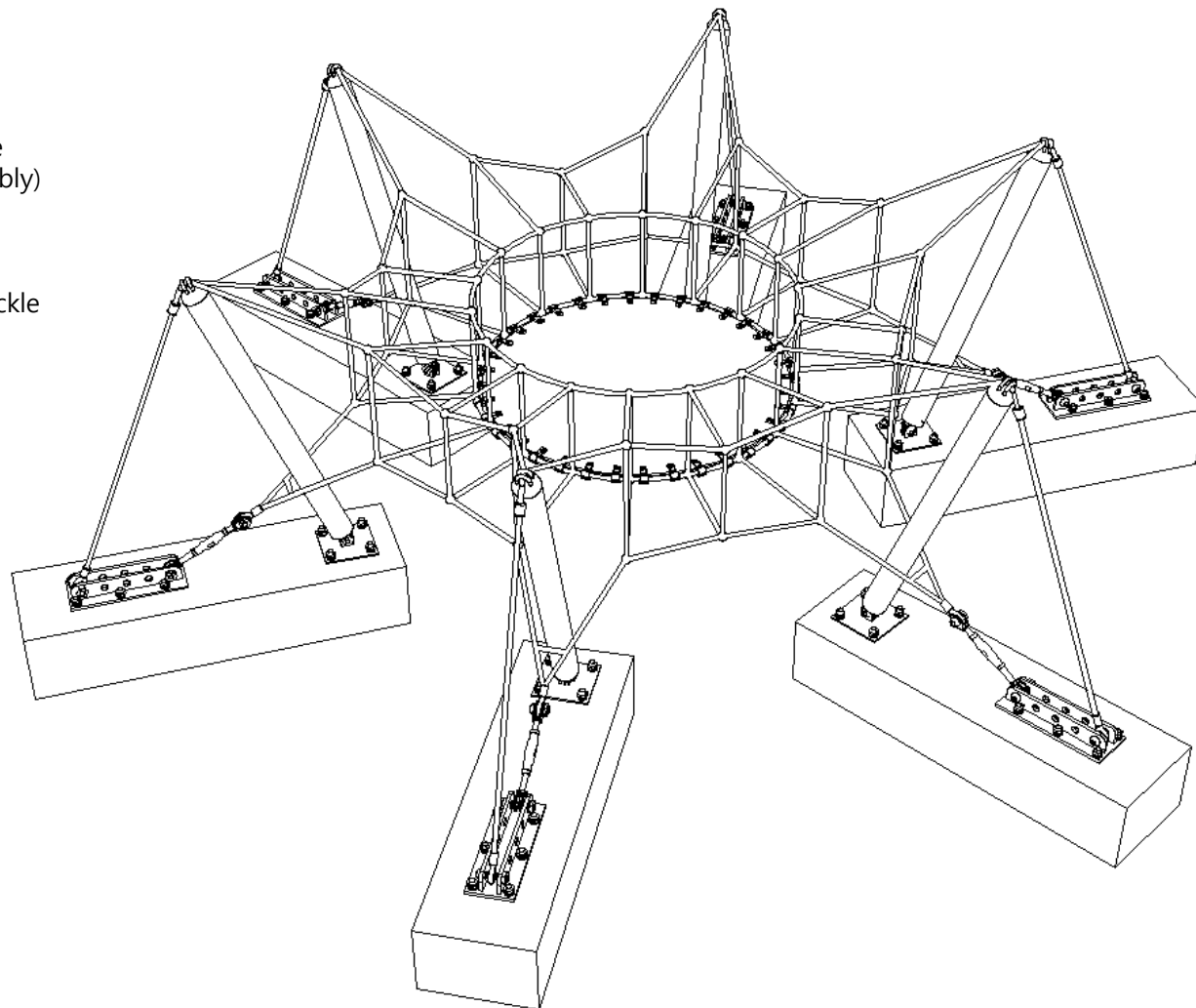

Caution!!

You have to construct foundation same level.
You have to keep foundation certain distance.

Features

The series is a specialty climbing structure featuring a flexible center area surrounded by netting. It is made of steel-loaded Nylon cables with UV guard and the landing surface is a textile-reinforced flexible rubber material.

The GS-W5001 features GS Web technology which includes the highest steel content and the strongest connection materials in the industry, including a steel-wire core in our edge ropes and connection points crushed in place with over 75 tons of pressure to ensure long life of the games and maximum safety for the children.

GS Web Nets help bring movement, balance, exercise and fun back into the playground.

Ages : 5 to 12 years

Capacity : 13 children

Size : D : 18' 5" / 5.60m

H : 4' 0" / 1.20m

Use zone (EN) : D : 28' 3" / 8.60m

Use zone (ASTM) : D : 30' 5" / 9.26m

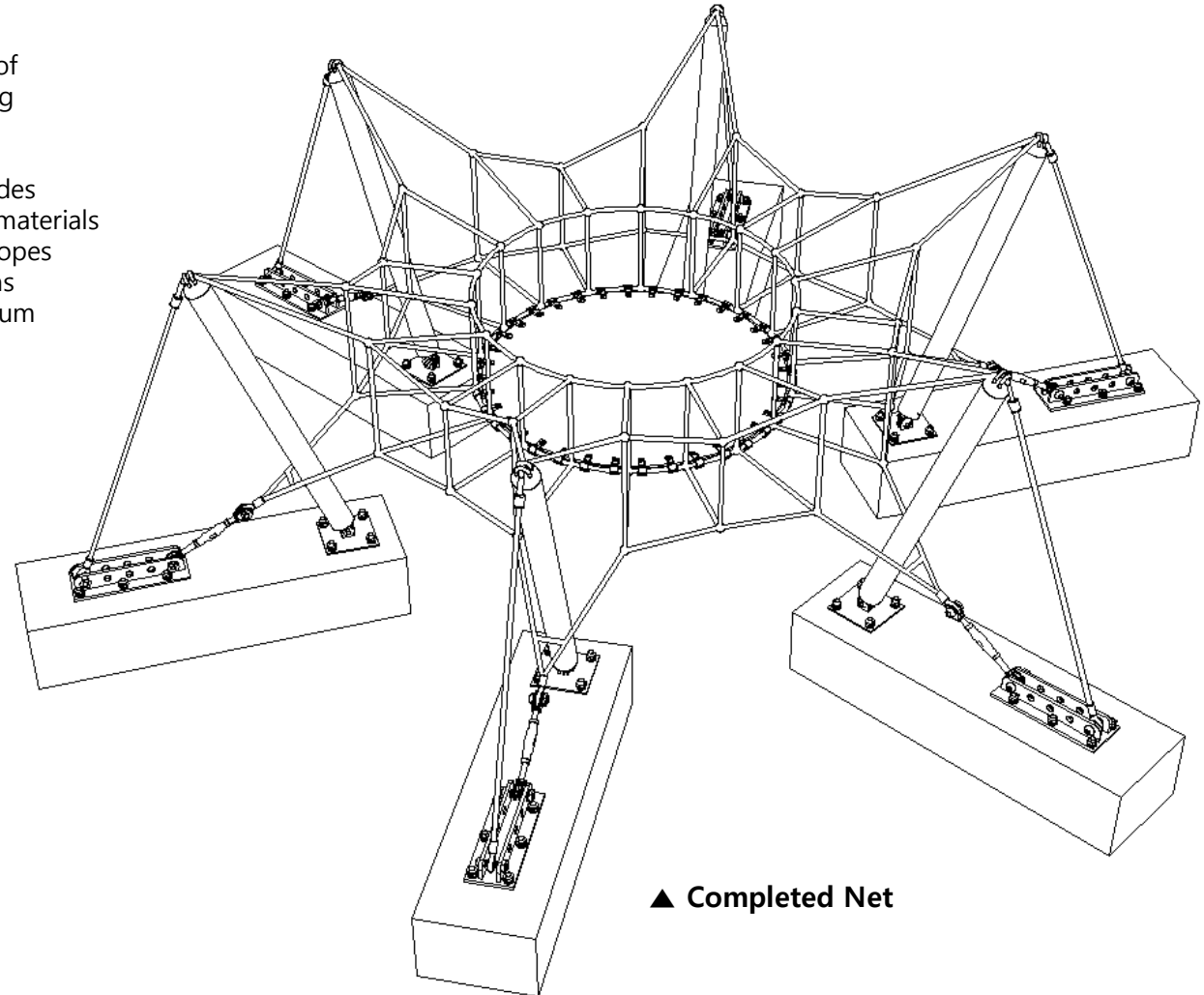

▲ Completed Net

Safety area

The requirements for space and safety clearances are taken from BS-EN 1176-1 / ASTM-F1487 / CSA Z614
 The use zone for stationary play equipment shall extend no less than 72 in. (1830mm) from all sides of the play structure.

Fall Height : 1250mm (from surface)

▼ Fall Height and safety area

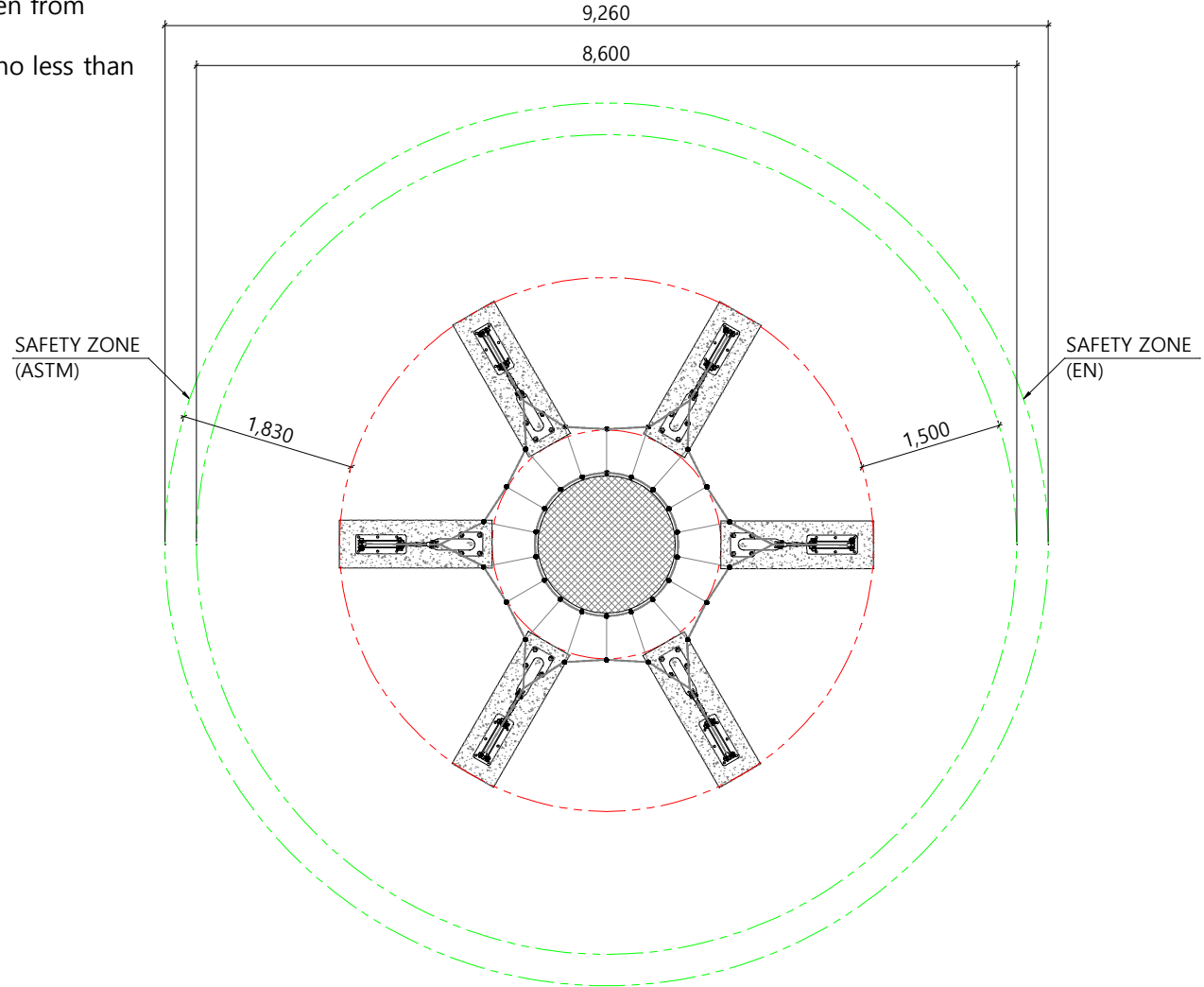
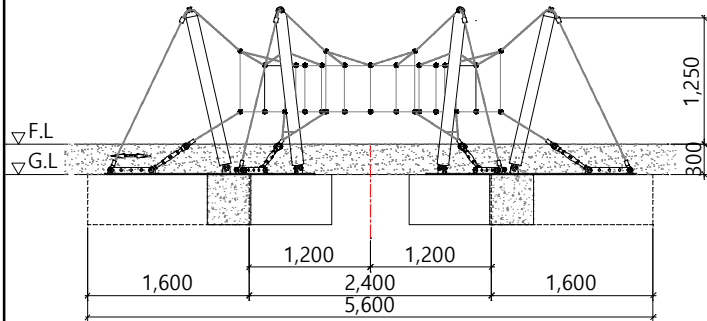

Foundation

Please refer to GS-W5001 drawing for exact installation dimensions

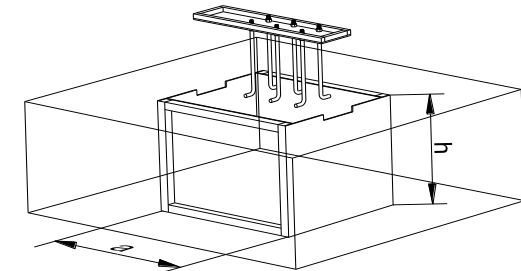
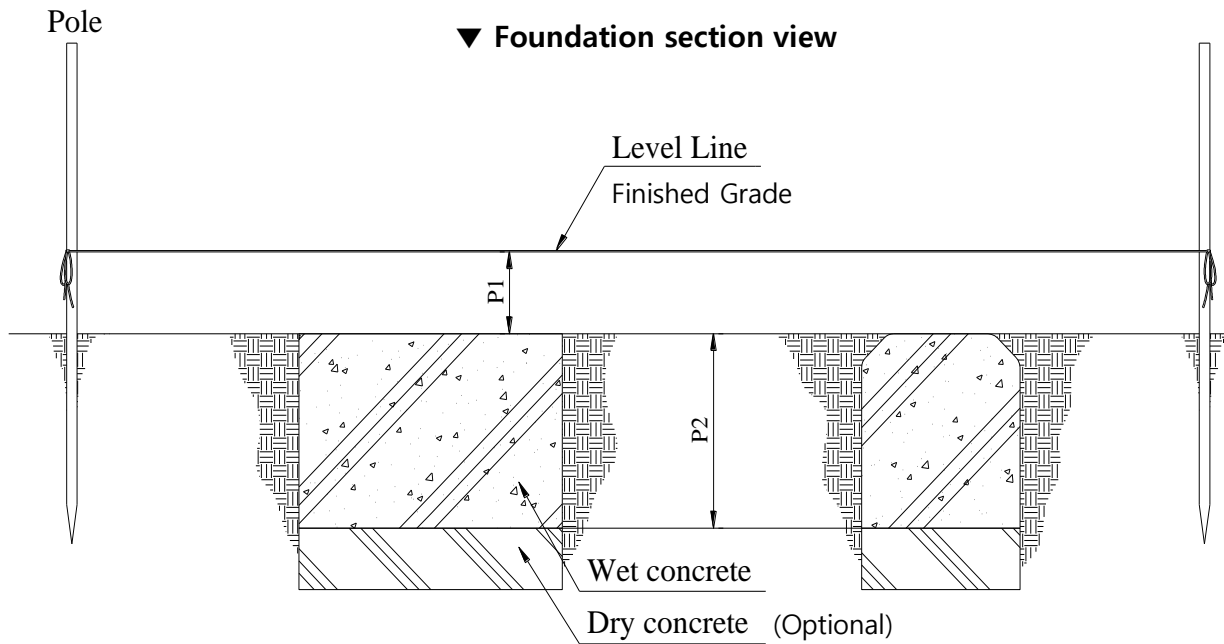

▲ Excavate enough materials to allow for proper depth of concrete footings

Also ensure that there is enough space to allow the frame to be positioned properly.

Anchor wood support frame to ground with pickets to prevent the frame from moving while concrete is poured and sets.

P1 = Depth below finished Grade (12" / 300mm)
P2 = Depth of concrete footing (19-2/3" / 500mm)

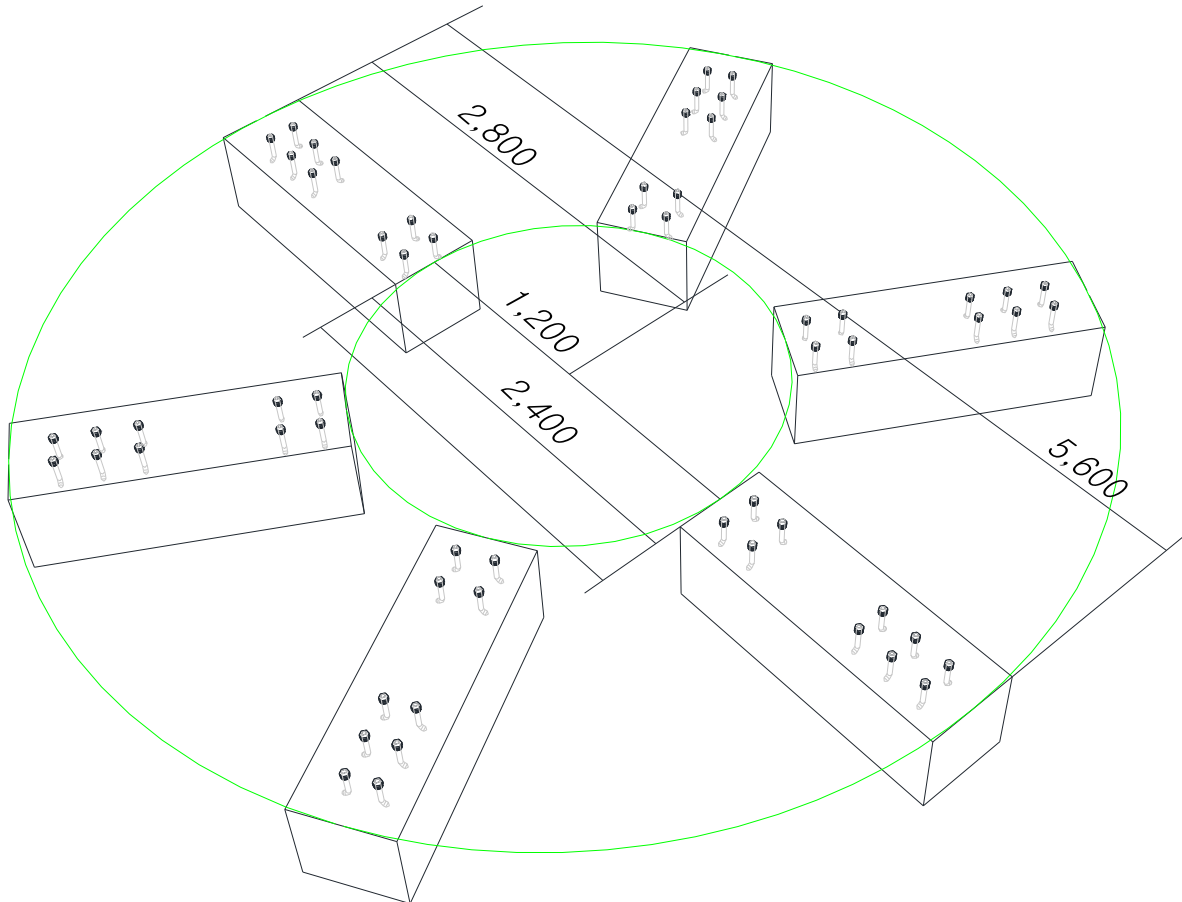

▲ Concrete footing and Anchor plate layout

Note Total distance from front of block to front of block is 7' 10" (2400mm)

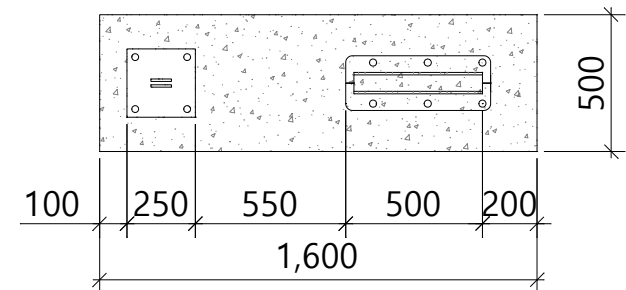

▲ Positioning Anchor plate on footing

Assemble wooden support frames *
6 frames (5' 3" / 1600mm L x 1' 8" / 500mm W x 1' 8" / 500mm H)

*Use 1/2" (min) plywood; not included in package

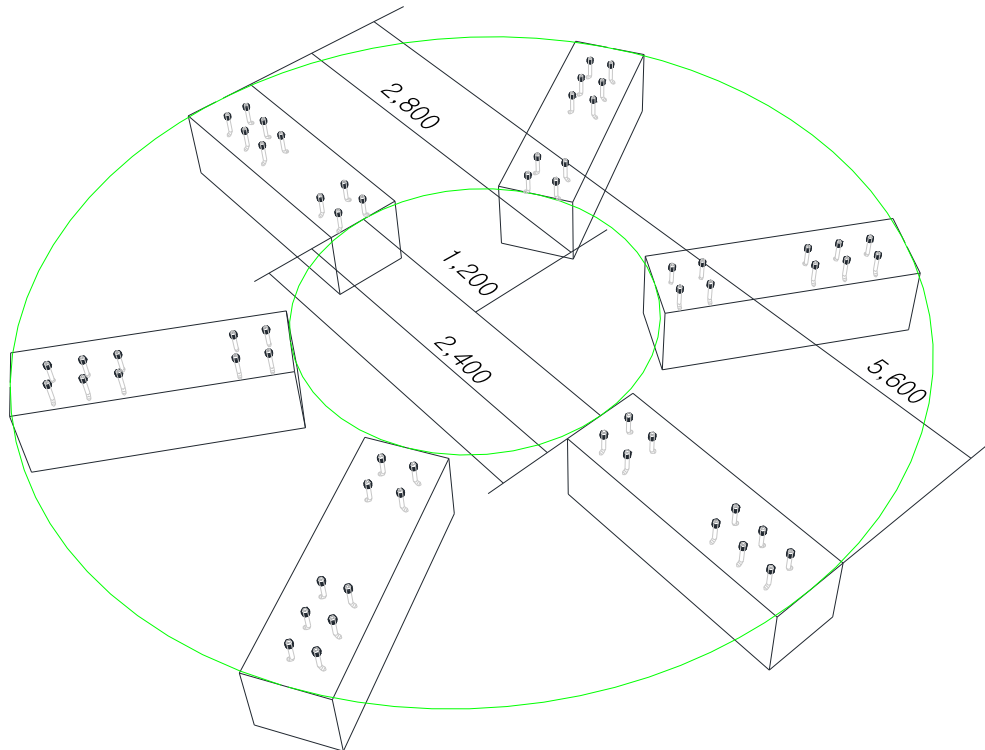

▲ Concrete footing

[Concrete]

Pour concrete* into wooden support frame until flush to top edge
Allow 3-5 days for concrete to cure before proceeding to next step

*Concrete is to be wet concrete with minimum **25 MPA / 3500PSI**

Remove wood support frame from dry concrete blocks

After concrete has cured enough, remove frame and replace soil in area around footing to subgrade level

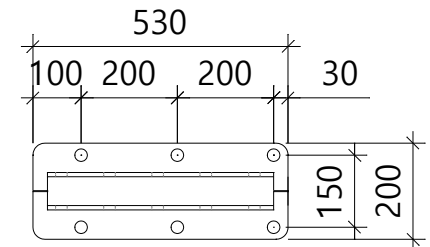
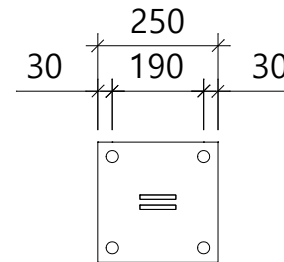

NOTE: Use anchor plate as guide for exact measurements.

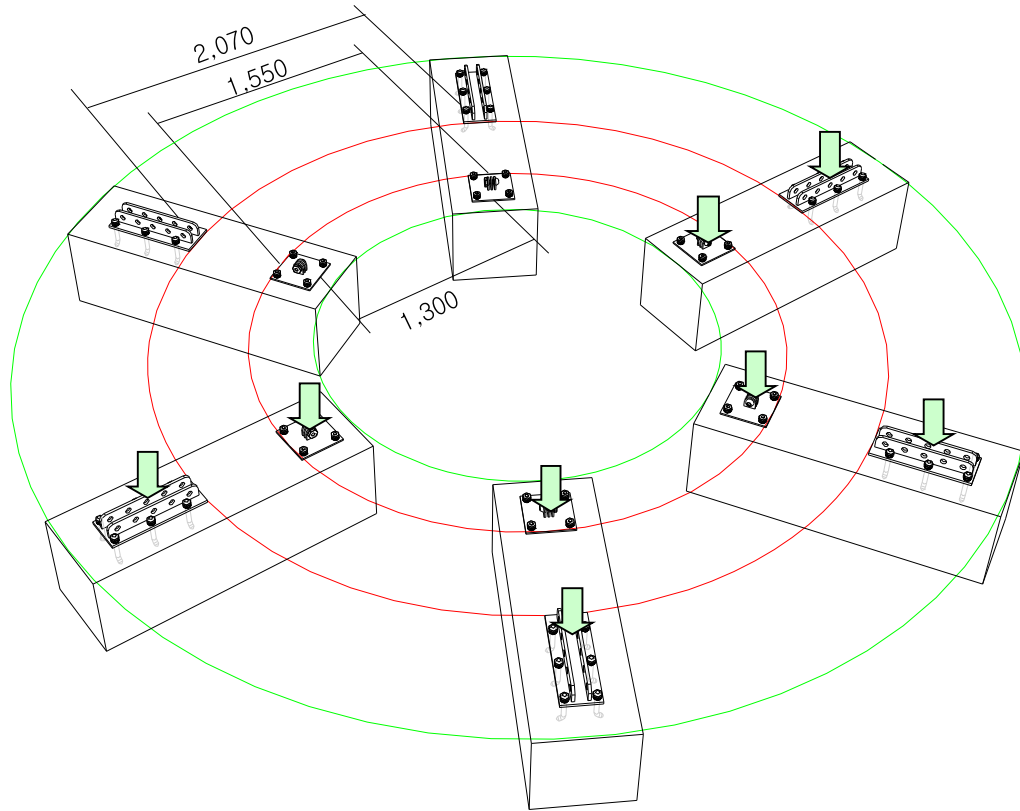
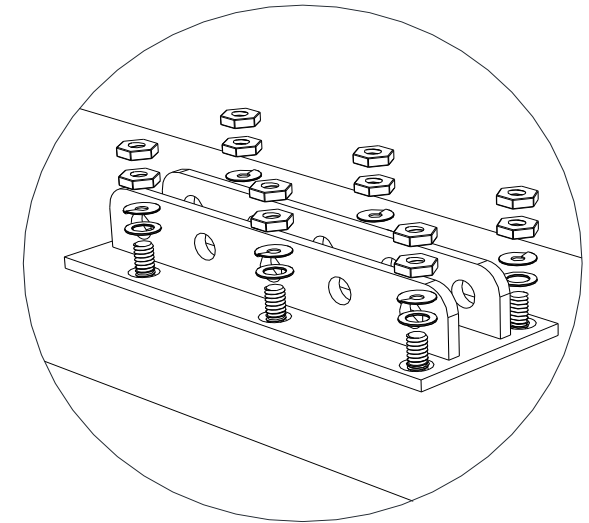
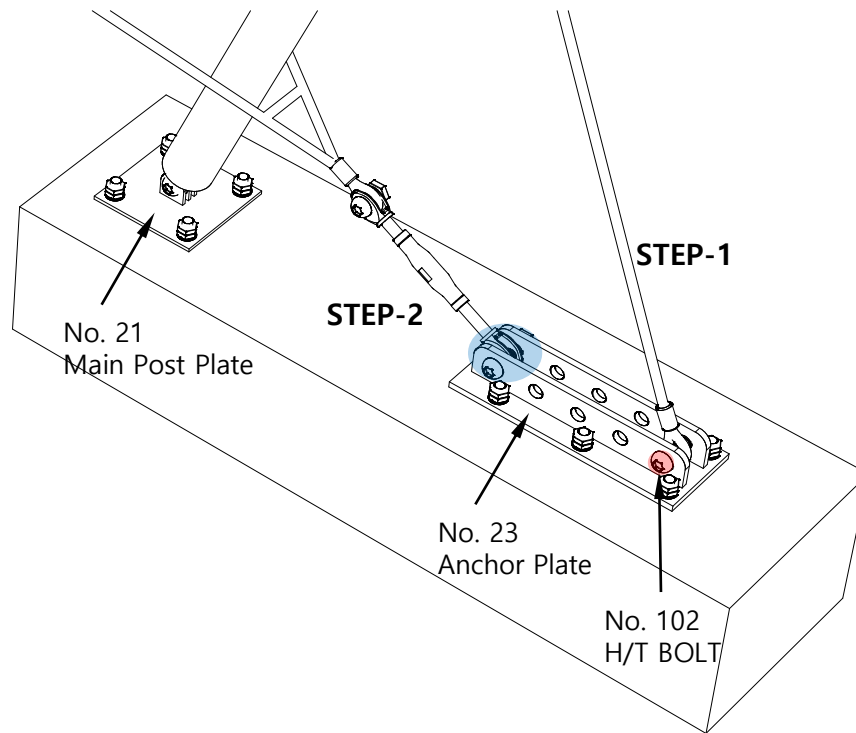

Plate Assembly

Concrete block-clean threads of "L" anchor bolts.
Attach Anchor plate to footing



▲ Attach Anchor plate to footing with flat washer, locking washer and nut



◀ **Attach Turnbuckle and rope**

Main rope joint

Step 1: Attach top rope with M22 X L110 H/T BOLT as shown .

Step 2: Attach Turnbuckle to anchor plate with M22 X L110 H/T BOLT. (at the first hole)

Loosen Turnbuckle all the way (about 100mm), leaving only 4 or 5 threads attached

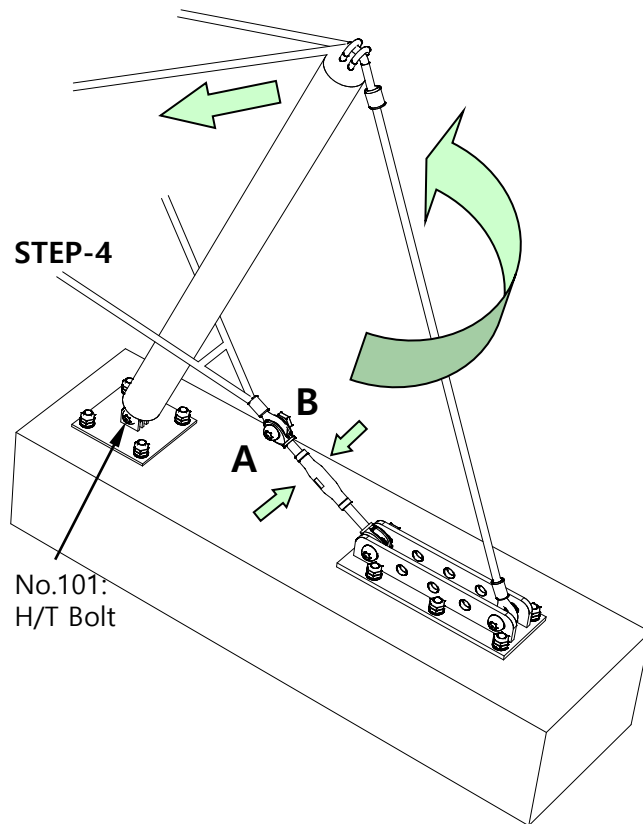

▲ Post assembly

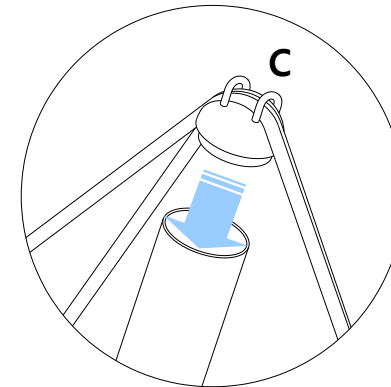

Note: Rubber mallet may be required to insert cap into post.

▲ Post cap assembly

Post assembly

- Step 3:** Attach Post Cap to Post
- Step 4:** Attach Post to Post base with M22 X L70 H/T BOLT

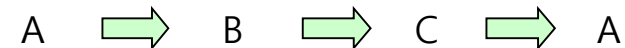

It is strongly recommended that 3-4 workers lift the net into place

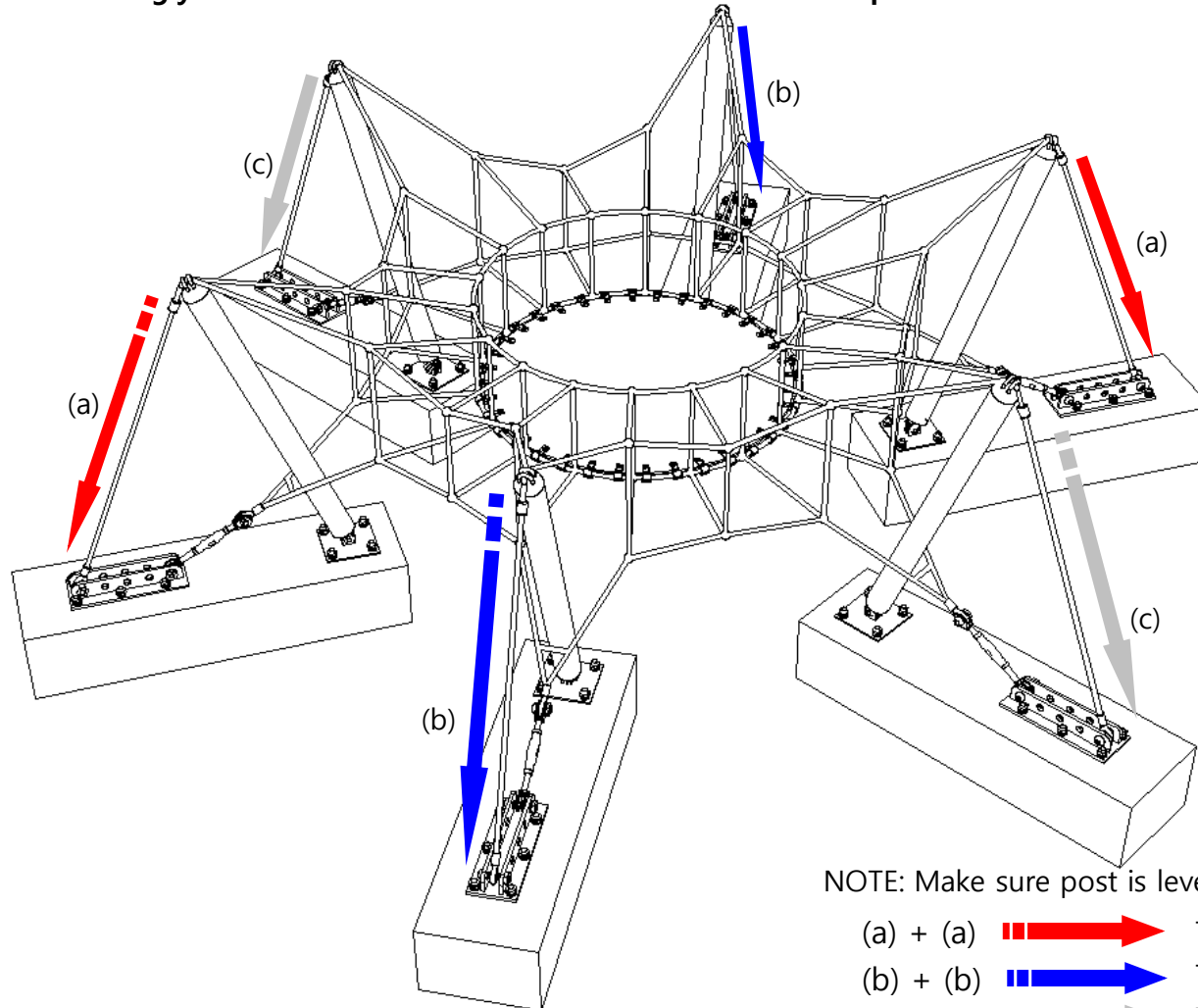

◀ Tightening Turnbuckles

NOTE: Make sure post is level before tightening and remains level during process.

- (a) + (a) Tighten Rope with Turnbuckles at the Same time
- (b) + (b) Tighten Rope with Turnbuckles at the Same time
- (c) + (c) Tighten Rope with Turnbuckles at the Same time

Maintenance information

Please tighten rope with Turnbuckle properly.
If you strain the net too much, it may cause damage.
It is also recommended that subsequent checks on tension should be carried out at monthly intervals and adjusted as required.
This will increase the overall longevity of the product.

Checking: 1 month

Refer to IPEMA and TUV maintenance system.

After Net structure tension is completed, the net will stretch slightly over the first four weeks of use.
Following this initial period, the net needs to be fully re-tensioned by Turnbuckle after 1 year.

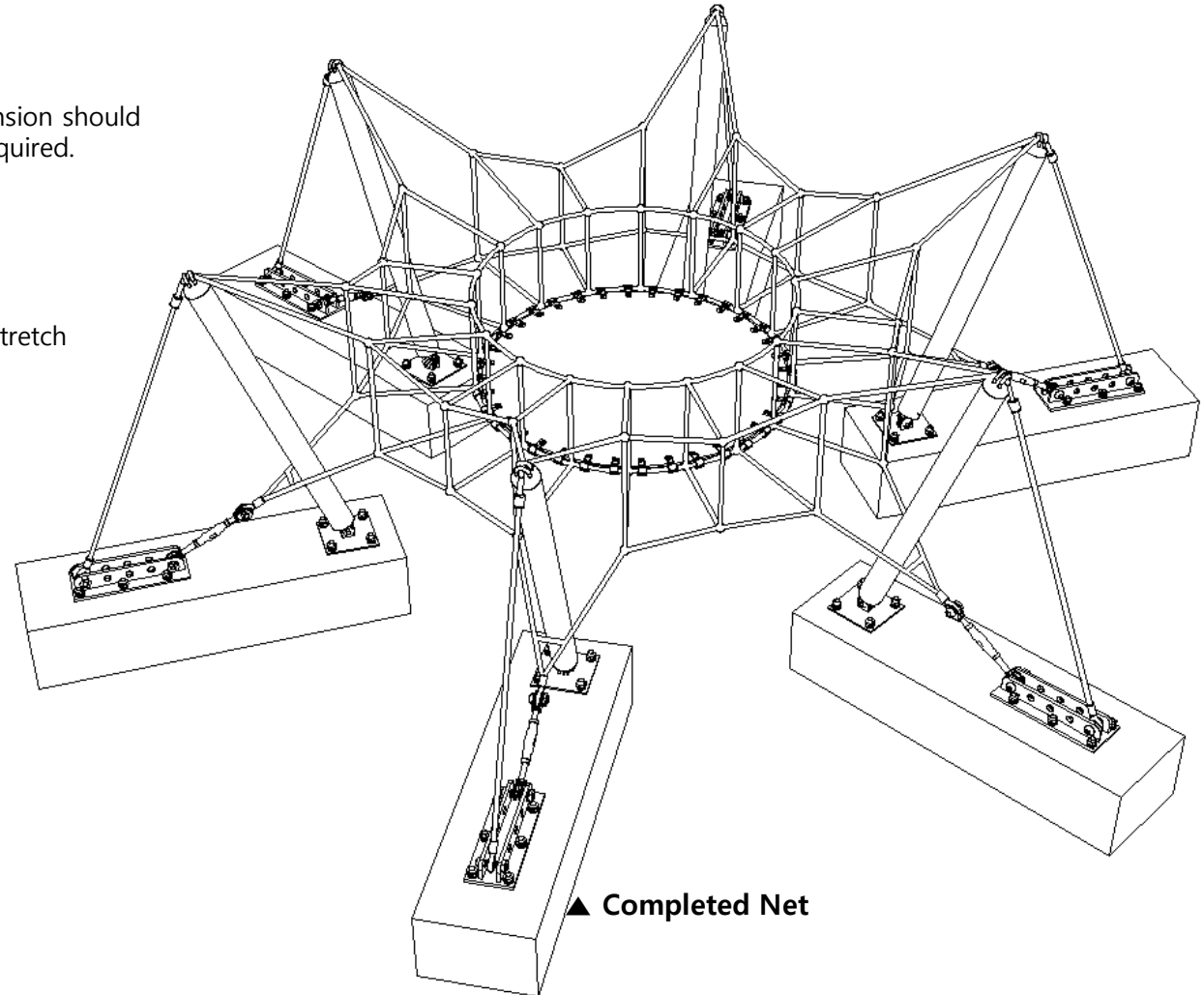

Parts check list

- | | |
|------------------------|-------------------|
| A. Multi Compound Rope | 61. Turn Buckle |
| 1. Main Post | 62. Post Cap |
| 21. Main Post Plate | 101. H/T Bolt Set |
| 23. Anchor Plate | 102. H/B Bolt Set |
| 41. L-Anchor Set | 103. U-Bolt Set |
| 42. L-Anchor Set | |

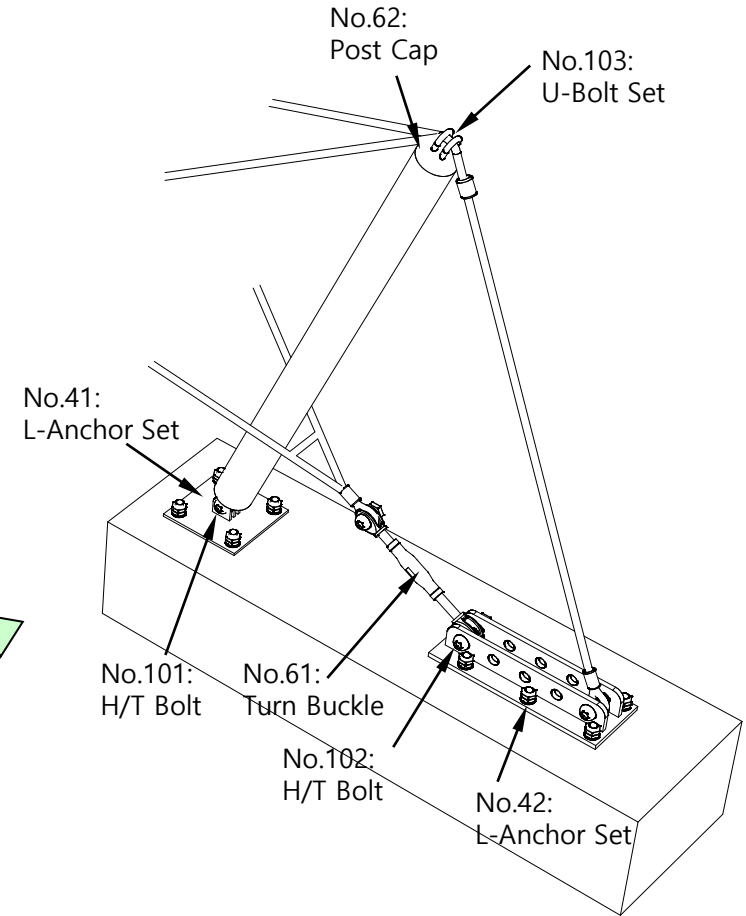
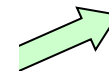
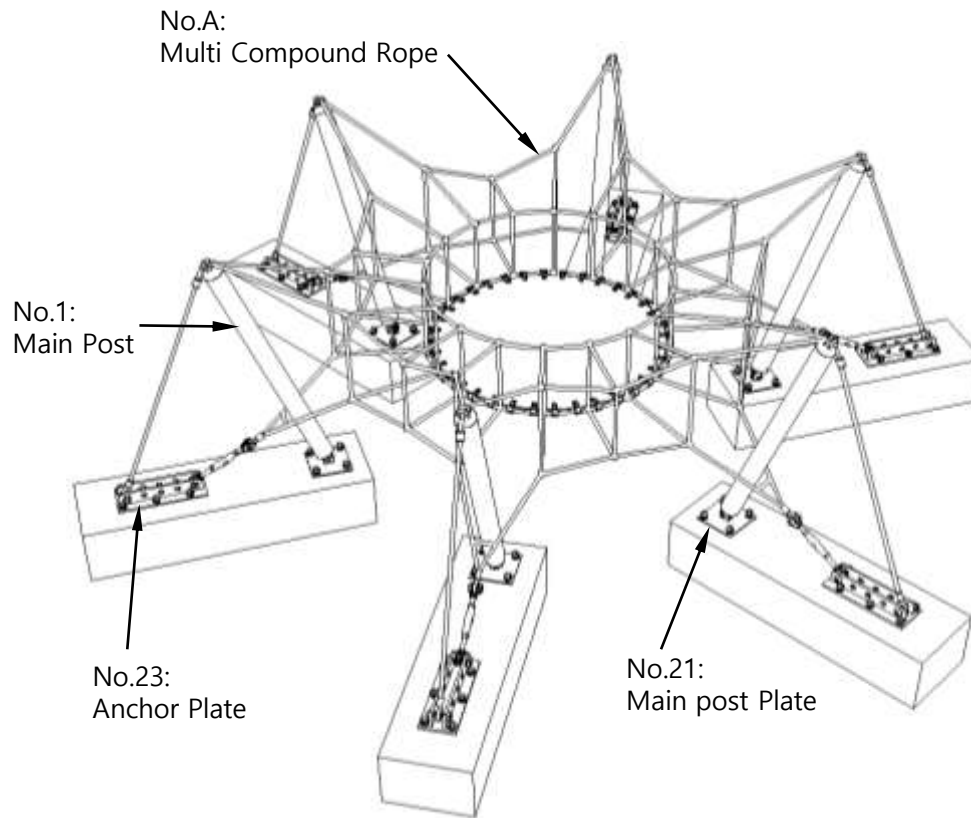

A. General safety measures

On the playground there should be a sign(pictogram) giving the following information:

- a) general emergency telephone number;
- b) telephone number to contact maintenance personnel;
- c) name of the playground;
- d) address of playground; and
- e) other relevant local information, if applicable.

The entry, exit and emergency paths to and from a playground, intended for use by the public and emergency services, should be accessible and free of obstacles at all times.

NOTE Attention is drawn to local regulations.

B. Procedures

Defects that occur during operation and which put safety at risk should be corrected without delay. If this is not possible, the equipment should be secured against use e.g. by immobilization or removal.

There should be written operational procedures covering the measures to be taken in the event of accidents, fire and the like.

Until unsafe equipment is repaired and released for use, access by the public should be prevented. Information about accidents brought to the attention of the manager should be recorded on a form that includes the following details:

- a) date and time of accident;
- b) age and sex of victim and clothing worn, including footwear;
- c) equipment involved;
- d) number of children on site at the time of the accident;
- e) description of accident;
- f) injury sustained including part(s) of body affected;
- g) action taken;
- h) witness statements;
- i) any subsequent equipment modification;
- j) weather conditions; and
- k) any other relevant information.

C. Routine maintenance

To reduce accidents, the owner or operator should ensure that an appropriate routine maintenance schedule is established, implemented and maintained. This should take into account local conditions and the manufacturer's instructions that can affect the necessary inspection frequency. The schedule should list the components to be maintained and should also give procedures for dealing with complaints and breakdowns.

The routine maintenance of playground equipment and surfaces should consist of preventative measures to maintain their level of safety, performance and compliance with the relevant part(s) of EN 1176. Such measures should include:

- a) tightening of fastenings;
- b) re-painting and re-treatment of surfaces;
- c) maintenance of any impact attenuating surfaces;
- d) lubrication of bearings;
- e) marking of equipment to signify loose fill finished surface level;
- f) cleaning;
- g) removal of broken glass and other debris or contaminants;
- h) restoring loose fills to the correct level; and
- i) maintenance of free space areas.

D. Corrective maintenance

Corrective maintenance should include measures to correct defects, or to re-establish the necessary levels of safety of the playground equipment and surfaces. Such measures should include:

- a) replacement of fastenings;
- b) welding of welding repairs;
- c) replacement of worn or defective parts; and
- d) replacement of defective structural components.

E. Personal safety

Repairs during operation that could put the safety of maintenance personnel of the public at risk, should be avoided.

F. Equipment alterations

Alterations to parts of a piece of equipment or structure that could affect the essential safety of the equipment should only be carried out after consultation with the manufacturer or a competent person.